

ISJ Series • ISDN S₀ DIL Style Through Hole Interface Transformers

Features

- Designed for optimum compatability with all established interface IC's
- Excellent and consistent balance between windings
- Complies fully with CCITT.I.430 recommendations and corresponding national standards for S-Interface
- Manufactured in ISO 9001:2015 and ISO 14001:2015 certified Talema facility
- Operating temperature: 0 to 85°C
- Fully RoHS & REACH Compliant and meets lead free reflow level J-STD-020F

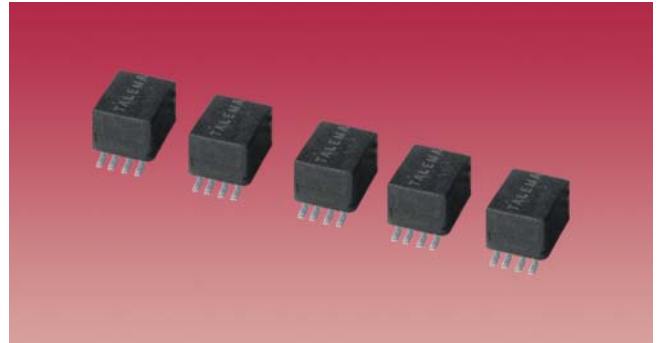

Electrical Specifications @ 25°C

Turns Ratio: **Bold** = IC side windings

ISJ Series comply with Basic Insulation Level EN60950, UL1950 and UL1450

Part Number	L _P (mH Min)	Turns Ratio	L _L (μH)	I _{DC} (mA)	C _C (pF Max)	R _{CU} P (Ohms)	R _{CU} S (Ohms)	V _P (Vrms)
ISJ-100B	25	1:1:1:1	2	--	60	4.2	4.2	1500
ISJ-140B	25	1:1:2:2	2	--	50	4.3	9.9	1500

Test Conditions:

Inductance: Line side windings in series - measurement @ 10KHz/100mV

Polarity and turns Ratio: Pins 1-2 : 3-4 : 5-6 : 7-8

Coupling capacitance: IC side windings in series to Line side windings in series - measurement @10KHz/100mV

Leakage Inductance: Line side windings in series, IC side windings short circuited - measurement @ 100KHz/100mV

Test Voltage: 1.5K for 2 Sec. - Line side windings in series to IC side windings in series.

Standard Packaging: Tape and Reel

Package Style

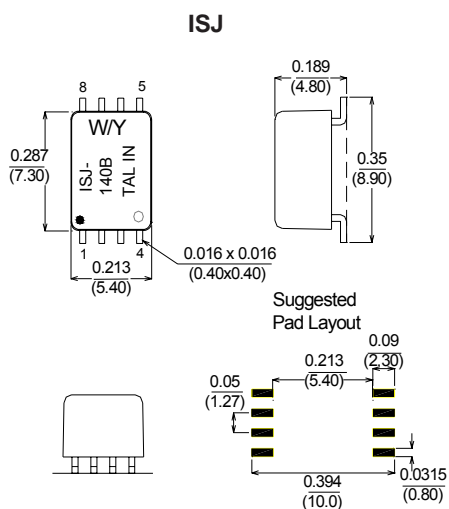

Schematic

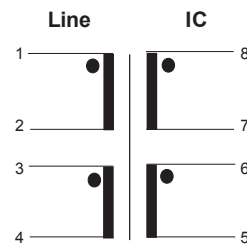

Dimensions: Inches (Millimeters)

Tolerance: ±0.010 (0.25) unless specified otherwise

Surface Coplanarity will be 0.004 (0.10) maximum

Packing Method: Tape and Reel; Qty/Reel: 1000 Pcs

Regional Locations - Design, Manufacturing, Sales & Marketing

Talema Group Regional Offices

North America

**United States
(Sales & Marketing)**

Talema Group, LLC
 PO Box 935
 900 Innovation Drive
 Suite 120, Rolla
 Missouri 65402
 Tel: +1 573-303-3675
 E-Mail:
sales@talemagroup.com
 Web: www.talema.com

Asia

**India
(Design, Manufacturing, Sales & Marketing)**

Administrative Office
Talema Electronic India Private Limited
 Door No. 221, 1st and 2nd Floor
 KJ Plaza, Opp.to Vidya Mandir School
 Meyanoor Main Road
 Salem - 636 004 Tamil Nadu INDIA
 Tel: +91 427 - 243 3100
 Fax: +91 427 - 243 3109
 E-Mail: talema@talemaindia.net
 Web: www.talema.com

Factory Premises
Talema Electronic India Private Limited
 Plot Nos. 30, 31 Electrical and Electronic
 Industrial Estate
 Suramangalam
 Salem - 636 005 Tamil Nadu INDIA
 Tel: +91 427 - 243 3000
 E-Mail: talema@talemaindia.net
 Web: www.talema.com

Europe

**Germany
(Design, Sales & Marketing)**

Talema Elektronik GmbH
 Sembdnerstr. 5
 82110 Germering
 Tel: +49 89 - 841 00 - 0
 Fax: +49 89 - 841 00 25
 E-Mail: info@talema.de
 Web: www.talema.com

**Ireland
(Design, Sales & Marketing)**

Nuvotem TEO
 Units W & X, Gweedore Business Park
 Derrybeg, Letterkenny, Co. Donegal
 Tel: +353 (0) 74 95 48666
 Fax: +353 (0) 74 95 48139
 E-Mail: info@nuvotem.com
 Web: www.nuvotem.com

**Czech Republic
(Design, Manufacturing, Sales & Marketing)**

NT Magnetics s.r.o.
 Chebská 27
 322 00 Plzeň
 Tel: +420 377 - 338 351
 Fax: +420 377 - 338 350
 E-Mail: talema@talema.cz
 Web: www.ntmagnetics.cz

Locations of Talema Group Regional Offices

